

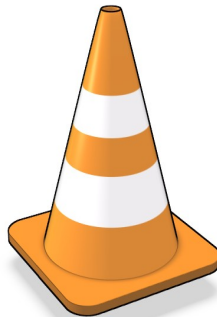

Streaming Networks with VLC

Jean-Paul Saman
jean-paul.saman@m2x.nl





- Jean-Paul Saman
 - 2001 member of VideoLAN team
 - PDA port (familiar linux distro)
 - H3600/3800/3900
 - VideoLAN server
 - Remote OSDmenu
 - DVB-C/S/T
 - DV camcorder



- M2X is specialized in
 - Multimedia,
 - Embedded and
 - Networking solutions
 - using Open Source software.



- VideoLAN project history
 - 2001 first release under GPL
 - 2003 VLC becomes a streamer
 - Complete multimedia client and server streaming solution

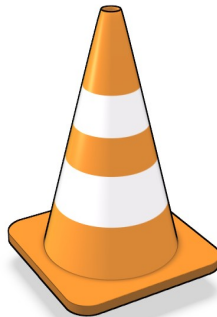



- VideoLAN deliveries:
 - VLC media player
 - Multimedia Player and Streamer
 - Version 0.8.5 has > 17 million downloads
 - Libdvdcss
 - Libdvbpsi
 - X264 (h264 encoder)

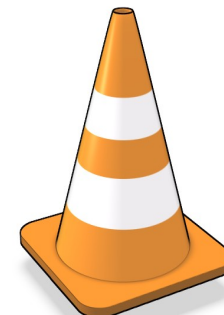



- VLC media player
 - Modular plugin architecture
 - Translated to more than 30 languages
 - Inputs (network, file, PVR cards, DVB, DVD, video4linux)
 - Codecs (MPEG 1/2/3/4, h264, wmv 1/2/3, QuickTime, OggVorbis, Theora, Dirac, 3GPP)
 - OS (MacOS X, Beos, Linux, Win32, *BSD, Solaris)



- Commercial products
 - Freebox (IPTV company)



- Google



- Di.com



- Neuf.tv (IP TV company)







- Support for IPv4 and Ipv6 networks
 - Small networks (SOHO)
 - 10 – 100 Mbits/sec
 - Coporate networks (LAN)
 - 100 – 1000 Mbits/sec
 - Large networks (WAN)
 - > 1000 Mbits/sec

Streamers

Clients

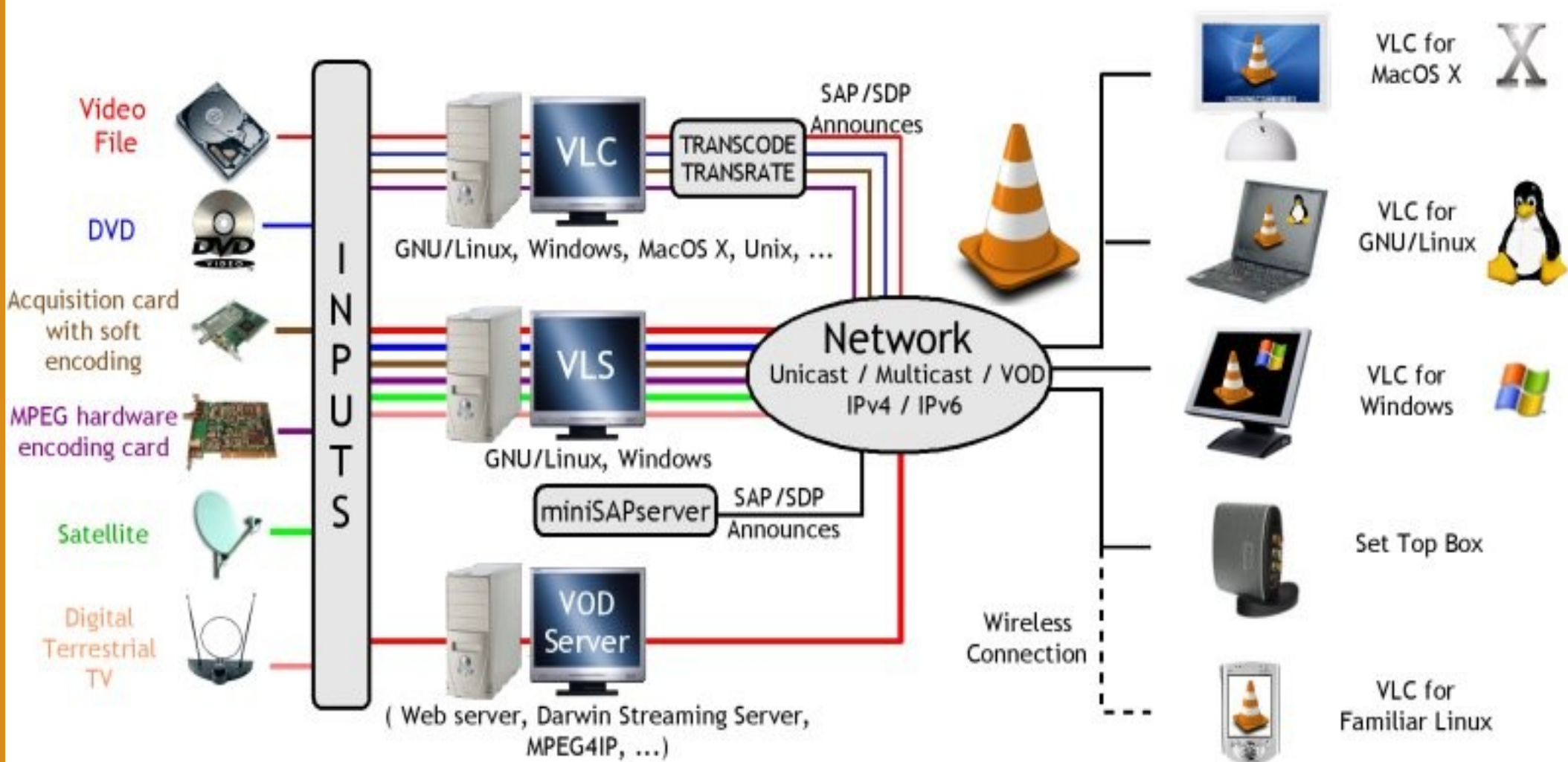



- Support various inputs
 - DVD
 - DVB C/S/T/(H)
 - Cable
 - Satellite
 - Terrestrial
 - Handheld
 - HW encoders (Acquisition cards)
 - Files and fifos
 - DV Camcorders/Webcams



- Streaming types
 - Unicast
 - Connection per client
 - Broadcast
 - Everybody gets the same
 - Multicast
 - Everybody gets the same on request
 - Video On Demand
 - On user request



- Unicast

- Network protocol

- UDP

- RTP

- Example:

- server:

- ```
vlc dvd:///dev/dvd -sout
```

- ```
'#std{access=udp,mux=ts,dst=192.168.0  
.30}'
```

- as client:

- ```
vlc udp://
```

# M2X

MULTIMEDIA 2 UNIX





- Broadcast

- Network protocol

- UDP

- RTP

- Example:

- server:

- `vlc file.mpg –sout`

- `‘#std{access=udp,mux=ts,dst=192.168.0`  
`.255}’`

- as client:

- `vlc udp://`

# M2X

MULTIMEDIA 2 UNIX



GNU/Linux, Windows, MacOS X, Unix,







- Multicast

- Network protocol

- UPD / RTP

- Need multicast route and network equipment

- Example:

- server:

- ```
vlc file.mpg -ttl 3 -sout
```

- ```
'#std{access=udp,mux=ts,dst=239.255.255.184}'
```

- as client:

- ```
vlc udp://@239.255.255.184:1234
```



- Need multicast route:

```
$> /sbin/route add -net 224.0.0.0 netmask 240.0.0.0 dev eth0
```

```
$> /sbin/route
```

Kernel IP routing table

Destination	Gateway	Genmask	Flags	Metric	Ref	Use	Iface
192.168.0.0	*	255.255.255.0	U	0	0	0	eth0
169.254.0.0	*	255.255.0.0	U	0	0	0	eth0
224.0.0.0	*	240.0.0.0	U	0	0	0	eth0
default	192.168.0.250	0.0.0.0	UG	0	0	0	eth0



Multicast ip-addresses

- 224.0.0.0/24 LAN protocol traffic between routers and switches
- 224.0.1.0/24 Internet protocol traffic between routers and switches
- 224.0.2.0 – 238.255.255.255 DON'T USE
- **239.0.0.0 – 239.255.255.255 Addresses for local use within a domain**

M2X

MULTIMEDIA 2 UNIX

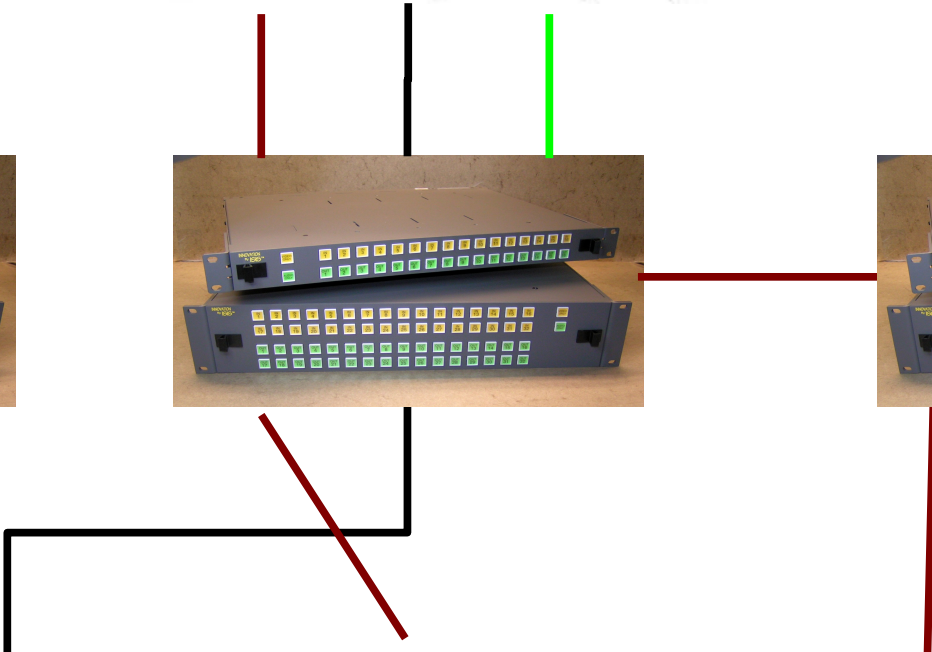



- Video On Demand
 - Network protocol
 - RTSP
 - HTTP
 - MMS
 - Example:
 - server:
vlc -I telnet --rtsp-host 0.0.0.0:5554
 - as client:
vlc rtsp://192.168.0.5:5554/stream



- Video On Demand

- Network protocol

- RTSP
 - HTTP
 - MMS

- Example:

- Server:

- ```
vlc file.ogg -sout
```

- ```
'#std{access=http,mux=ogg,dst=0.0.0.0:8080}'
```

- as client:

- ```
vlc http://localhost:8080/
```

# M2X

MULTIMEDIA 2 UNIX



TRANSCODE  
TRANSRATE

GNU/Linux. Windows, MacOS X, Unix,





- Video On Demand
  - VLC is able to announce its streams using:
    - SAP/SDP standard, or
    - Zeroconf (also known as Bonjour).





- Bandwidth
  - Network bandwidth
    - NIC max 100 Mb/s
    - Max load 80%
  - Multimedia bandwidth
    - Depends on encoder settings
    - Type of input source (file, dvb, dvd, encoder card, vcd, etc.)



- Network bandwidth
  - Rule of thumb 75-80% of NIC is available
  - Measure
    - Iperf (network throughput tester)
    - Iptraffic (shows used bandwidth)
  - Speed of NIC
    - Full duplex mode
    - Autonegotiation = no
    - Max speed (eg: 100 Mbit/s)



- Multimedia bitrate
  - MPEG-4 stream: 0.5 to 4 Mbit/s
  - MPEG-2 stream: 3 to 4 Mbit/s
    - from a satellite card,
    - digital television card,
    - MPEG-2 encoding card.
  - DVD: 6 to 9 Mbit/s
  - HD: 10 Mbit/s and up
  - Files: < 1 Mbit/s
  - Webcams: < 1 Mbits/s



- Bitrate terminology
  - Constant Bitrate (CBR)
  - Variable Bitrate (VBR)
    - Encoder encodes video frames into I, P or B frames
    - A stream consists of a sequence of I, P or B-frames with timestamps attached
    - Example for MPEG2-TS:

IPBBPBBBBPBBP



## Multimedia stream bandwidth

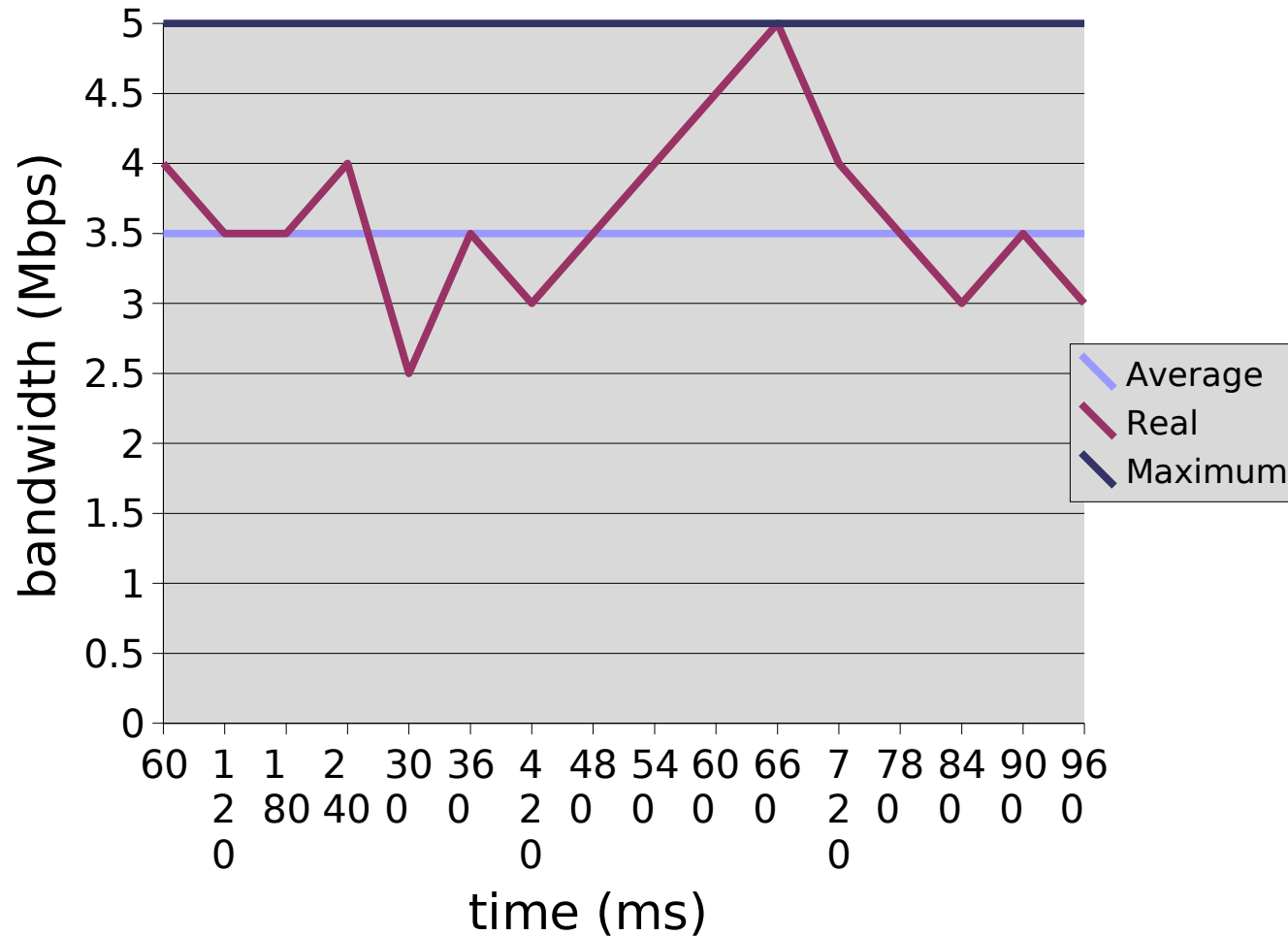



- Network troubles
  - Check logs
  - Keep it simple (test on localhost first)
  - Disable firewalls
  - Check network traffic
    - Wireshark/Ethereal
    - Tcpdump
      - Tcpdump -i eth0 port 1234

# M2X

MULTIMEDIA 2 UNIX





Filter:  + Expression... Clear

| No. - | Time     | Source        | Destination        | Protocol | Info            |
|-------|----------|---------------|--------------------|----------|-----------------|
| 1     | 0.000000 | Dell_69:b7:58 | Spanning-tree-(for | STP      | Conf. Root = 32 |
| 2     | 1.995923 | Dell_69:b7:58 | Spanning-tree-(for | STP      | Conf. Root = 32 |
| 3     | 3.991774 | Dell_69:b7:58 | Spanning-tree-(for | STP      | Conf. Root = 32 |
| 4     | 5.987475 | Dell_69:b7:58 | Spanning-tree-(for | STP      | Conf. Root = 32 |
| 5     | 7.983307 | Dell_69:b7:58 | Spanning-tree-(for | STP      | Conf. Root = 32 |



▶ Frame 1 (60 bytes on wire, 60 bytes captured)  
 ▶ IEEE 802.3 Ethernet  
 ▶ Logical-Link Control  
 ▶ Spanning Tree Protocol

```

0000 01 80 c2 00 00 00 00 14 22 69 b7 58 00 26 42 42 "i.X.&BB
0010 03 00 00 00 00 00 80 00 00 14 22 69 b7 4d 00 00 "i.M..
0020 00 00 80 00 00 14 22 69 b7 4d 80 0b 00 00 14 00 "i .M.....
0030 02 00 0f 00 00 00 00 00 00 00 00 00

```





- VLC stream output modules
  - Standard
  - Transcode
  - Duplicate
  - Mosaic\_bridge
  - Bridge
  - Rtp
  - Es
  - display
  - dummy



- Transcoding
  - Decoding audio/video from one format and encode it into another format
    - Video: MPEG-1/2/4, Divx 1/2/3, WMV 1/2, H264, MJPEG, Theora, ...
    - Audio: MPEG layer 2/3, AC3, MPEG-4, Vorbis, Flac, Speex, Faad2, Ogg, ...



- Transcoding

- Decoding audio/video from one format and encode it into another format

- Example:

```
vlc file.avi -sout
```

```
'#transcode{vcodec=mp2v,vb=1024,acodec=mpga,ab=192,channels=2}:
```

```
std{access=udp,mux=ts,dst=192.168.0.15}'
```

# M2X

MULTIMEDIA 2 UNIX

## Mosaïque

freeboxTV



2 FRANCE 2



3 FRANCE 3



5 FRANCE 5



6 EURONEWS



7 ARTE



8 DIRECT 8



9 W9



11 NT1



12 NRJ 12



13 LCP



14 FRANCE 4



16 RTL9



17 AB 1



18 TV5



19 PARIS PRE...



20 BLOOMBERG



21 CNBC



22 FRANCE Ô



23 DEMAIN !



25 CNN

❖ Sélection OK Valider

⏪ Précédent

⏩ Suivant



- Mosaic

- Uses fake: input module

- Example:

- Server:

```
vlc -I telnet -vlm-conf mosaic.conf -ttl=3 -
 mosaic-width 360 -mosaic-height 288 -
 mosaic-keep-picture -mosaic-rows 2 -mosaic-
 cols 2 -mosaic-position 1 -mosaic-order 1,2,3
 fake: --fake-file=v3-wallpaper_1280x1024.jpg
 --fake-fps=25.0 --fake-aspect-ratio="4:3"
```

as client:

```
vlc udp://
```



- Vlm-conf file “mosaic.conf”

```
new channel1 broadcast enabled
```

```
setup channel1 input udp://@239.255.2.60:1234
```

```
setup channel1 output #duplicate{dst=mosaic-
 bridge{id=1,height=144,width=180},select=video,dst=bri
 dge-out{id=1},select=audio}
```

```
....
```

```
new background broadcast enabled
```

```
setup background input fake:
```

```
setup background output
 #transcode{sfilter=mosaic,vcodec=mp2v,vb=10000,scale
 =1}:bridge-in{delay=400,id-
 offset=100}:standard{access=udp,mux=ts,url=239.255.1
 2.42,sap,name="mosaic"}
```

```
control background play
```

```
control channel1 play
```

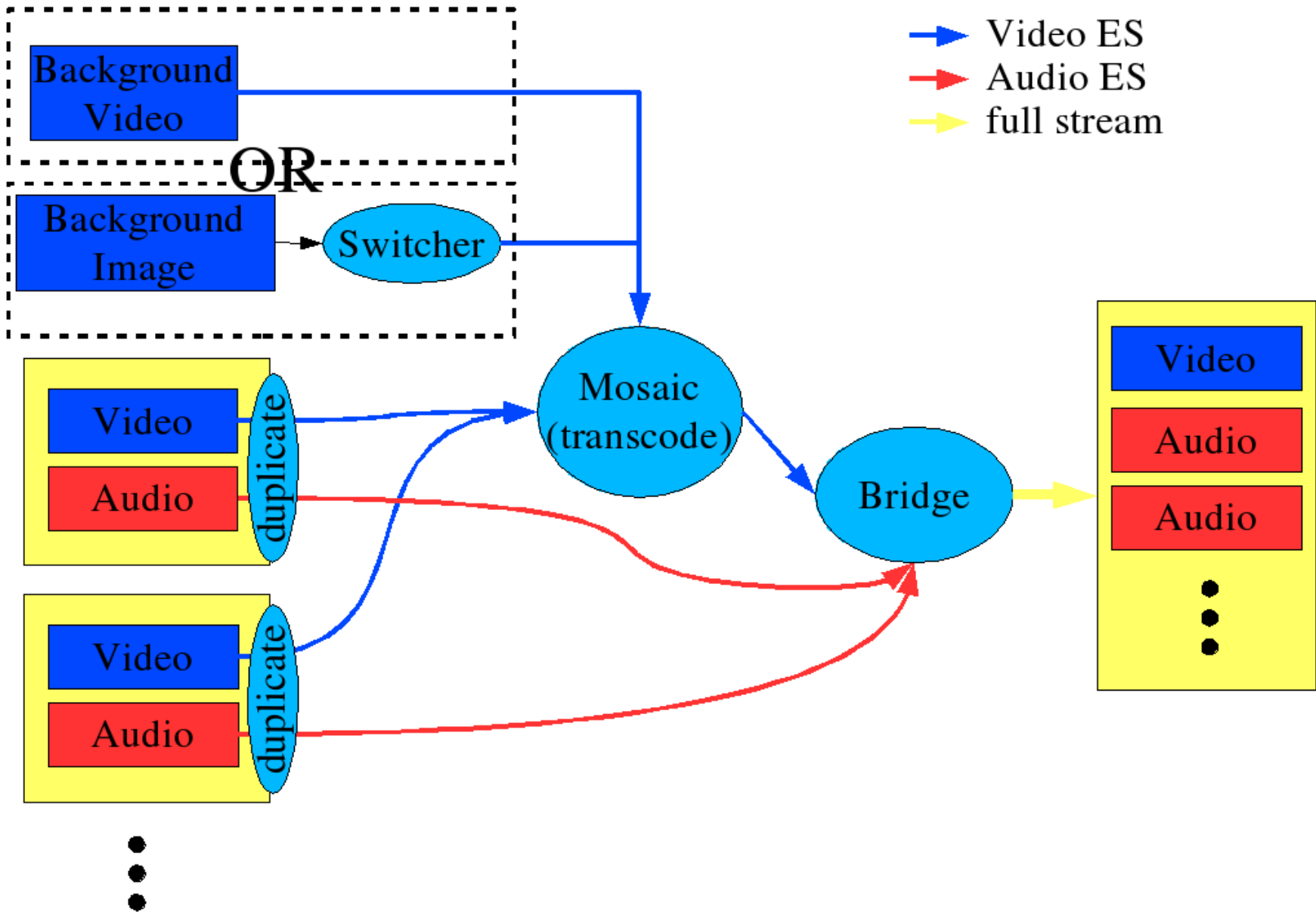



Questions ?

<http://www.videolan.org>

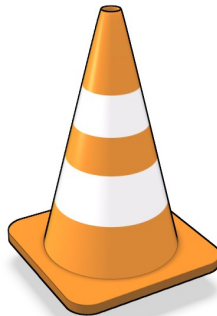

M2X

web: <http://www.m2x.nl>

e-mail: [jean-paul.saman@m2x.nl](mailto:jean-paul.saman@m2x.nl)